

ECE 5320

Lecture #8

Synthesis and Application of Magnetic Nanoparticles

Top → Down
Synthesis by Physical Methods

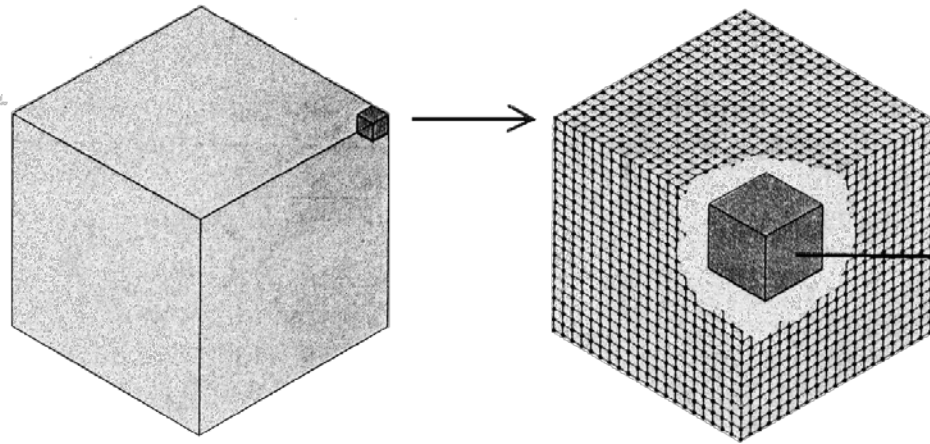

Bulk
 Classical behavior

Up ← Bottom
Synthesis by Chemical Methods

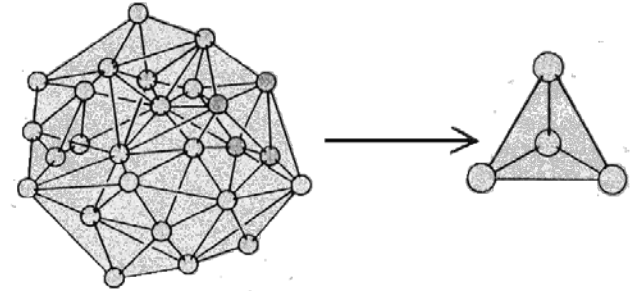

Nanoparticles
 Quantum-size effects

Molecules
 Quantum behavior

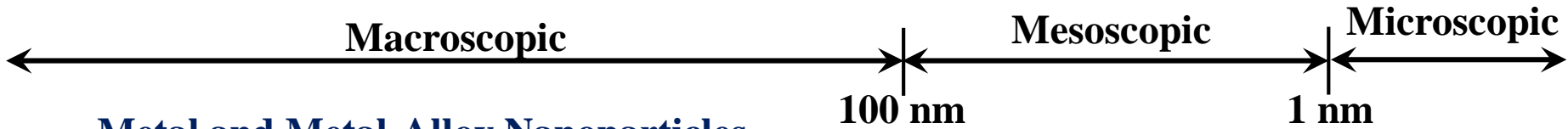

Metal and Metal-Alloy Nanoparticles

1. High Energy Ball Milling
2. Laser Ablation
3. Ion Sputtering
4. Thermal Evaporation
5. etc.....

Metal and Metal-Oxide Nanoparticles

1. Reduction of Metal Salts in Solution
2. Thermal Decomposition Reactions
3. Hydrolysis in Aqueous Solutions
4. Hydrolysis in Nonaqueous Solutions
5. etc.....

Nanoparticulate Magnetic Materials

Nanostructured

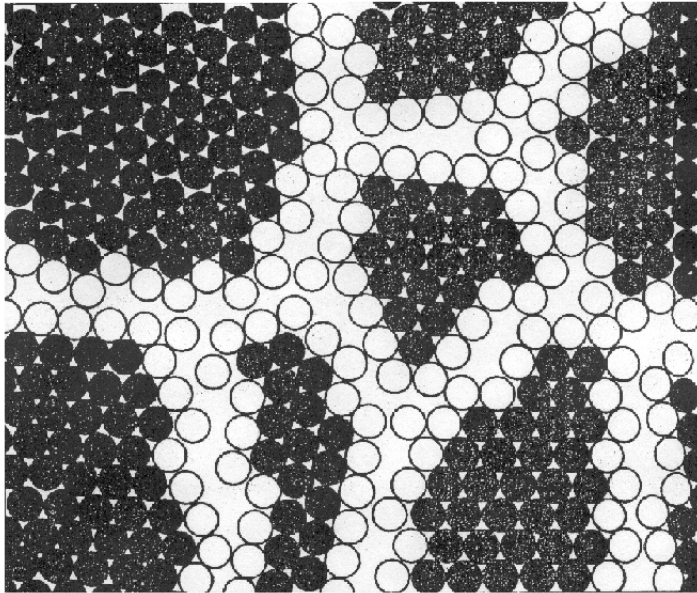

Abundance of grain boundaries

H. Gleiter, *Acta Mater.* 48, 1 (2000)

Nanocomposite

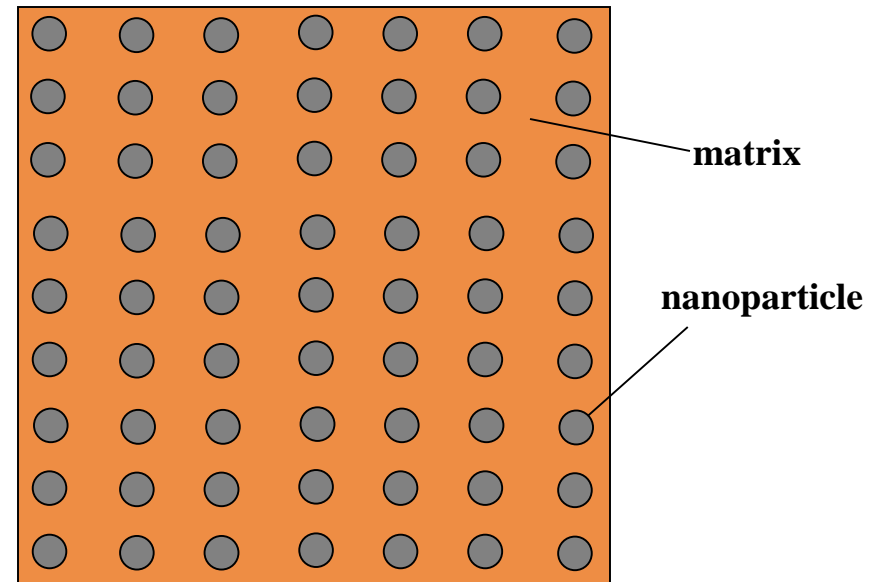

Abundance of interfaces

Novel magnetic properties engineered through tailoring of the grain boundary or interfacial region and through interparticle magnetic interactions. Particles can interact via short-range magnetic exchange through grain boundaries or long-range dipolar magnetic interactions.

General Concepts in Nucleation and Growth of Magnetic Nanoparticles

Nucleation and Critical Radii

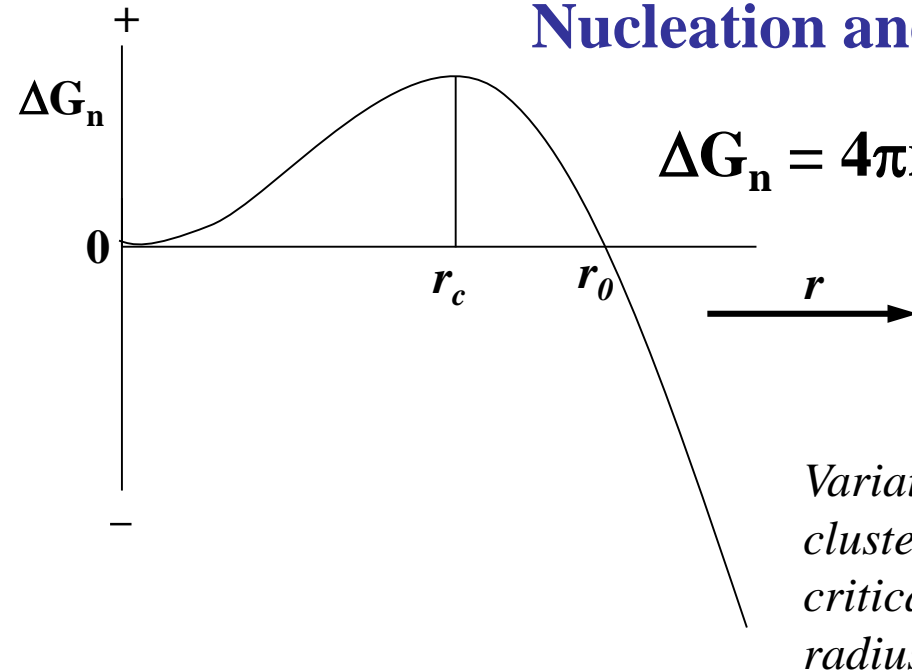

$$\Delta G_n = 4\pi r^2 \Delta G_s - (4/3)\pi r^3 \Delta G_v$$

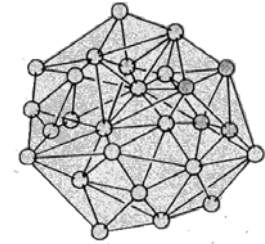

Variation of Gibb's free energy of nucleation with cluster radius during synthesis. r_c is the kinetic critical radius and r_0 the thermodynamic critical radius

Stabilization of nanoclusters of various size requires a competitive reaction chemistry between core cluster growth and cluster surface passivation by capping ligands that arrests further core growth.

V. K. LaMer and R. H. Dinegar, J. Am. Chem. Soc. 72 (1950) 4847

Surfactants

Magnetic nanoparticles can stick together if they collide. This can lead to agglomeration, which is generally detrimental for applications.

In order to prevent agglomeration, nanoparticles are often coated with some material to prevent agglomeration (either because of steric or electrostatic effects).

Organic surfactants. Normally long chain molecules, including fatty acids, dextran, alginate, or other polymers.

Inorganic surfactants. Generally non- or weakly-reactive materials, including Si, SiO₂, Au, or others. Core-shell nanoparticle structures can also have other types of functionalities (quantum dots).

Surfactants can also introduce additional binding sites to the magnetic nanoparticles.

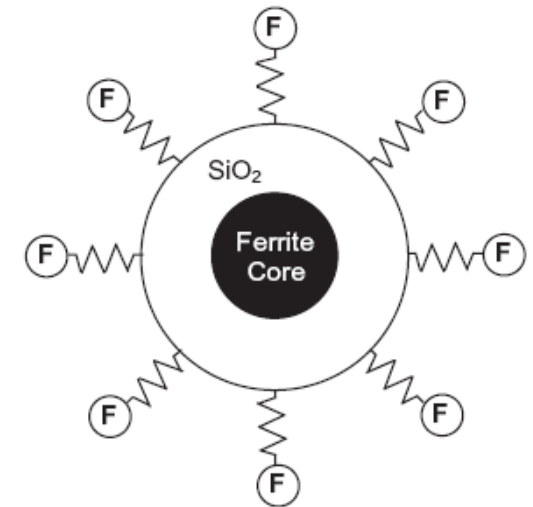

INSTITUTE OF PHYSICS PUBLISHING
J. Phys. D: Appl. Phys. 36 (2003) R167-R181

JOURNAL OF PHYSICS D: APPLIED PHYSICS
PII: S0022-3727(03)40035-1

TOPICAL REVIEW

**Applications of magnetic nanoparticles
in biomedicine**

Q A Pankhurst¹, J Connolly², S K Jones³ and J Dobson⁴

Monodispersed γ -Fe₂O₃ nanoparticles

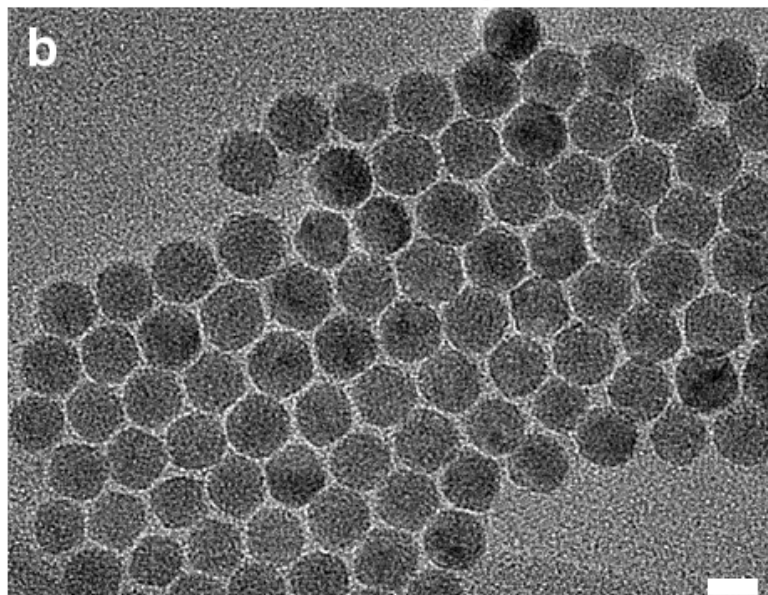
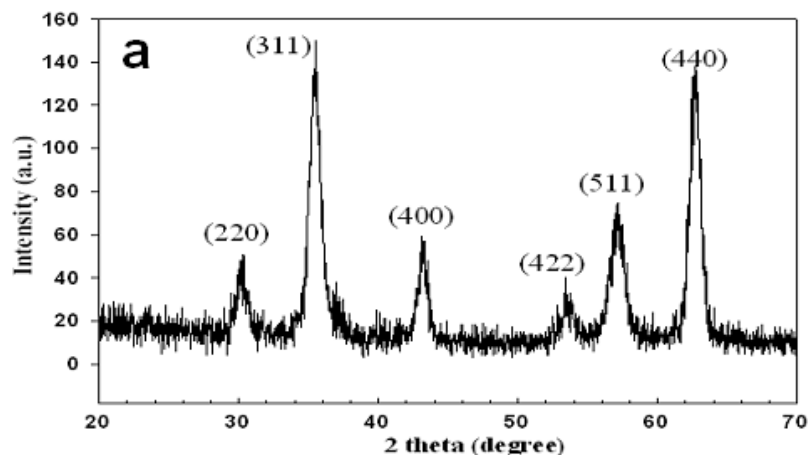

Thermal decomposition of iron pentacarbonyl, Fe(CO)₅, in the presence of oleic acid produced monodispersed metal iron particles. Controlled oxidation using trimethylamine oxide, (CH₃)₃NO, as a mild oxidant produced highly crystalline γ -Fe₂O₃ particles. The particles were in the size range 4 nm to 16 nm diameter depending on experimental conditions. Highly uniform, oleic acid covered, magnetic nanoparticles of γ -Fe₂O₃, $\sim(11.8 \pm 1.3)$ nm diameter are shown. XRD patterns confirm the presence of Fe₂O₃.

**D.K. Yi, S.S. Lee, G.C. Papaefthymiou,
J.Y. Ying, Chem. Mater. 18 (2006) 614**



TEM image of iron oxide nanoparticle

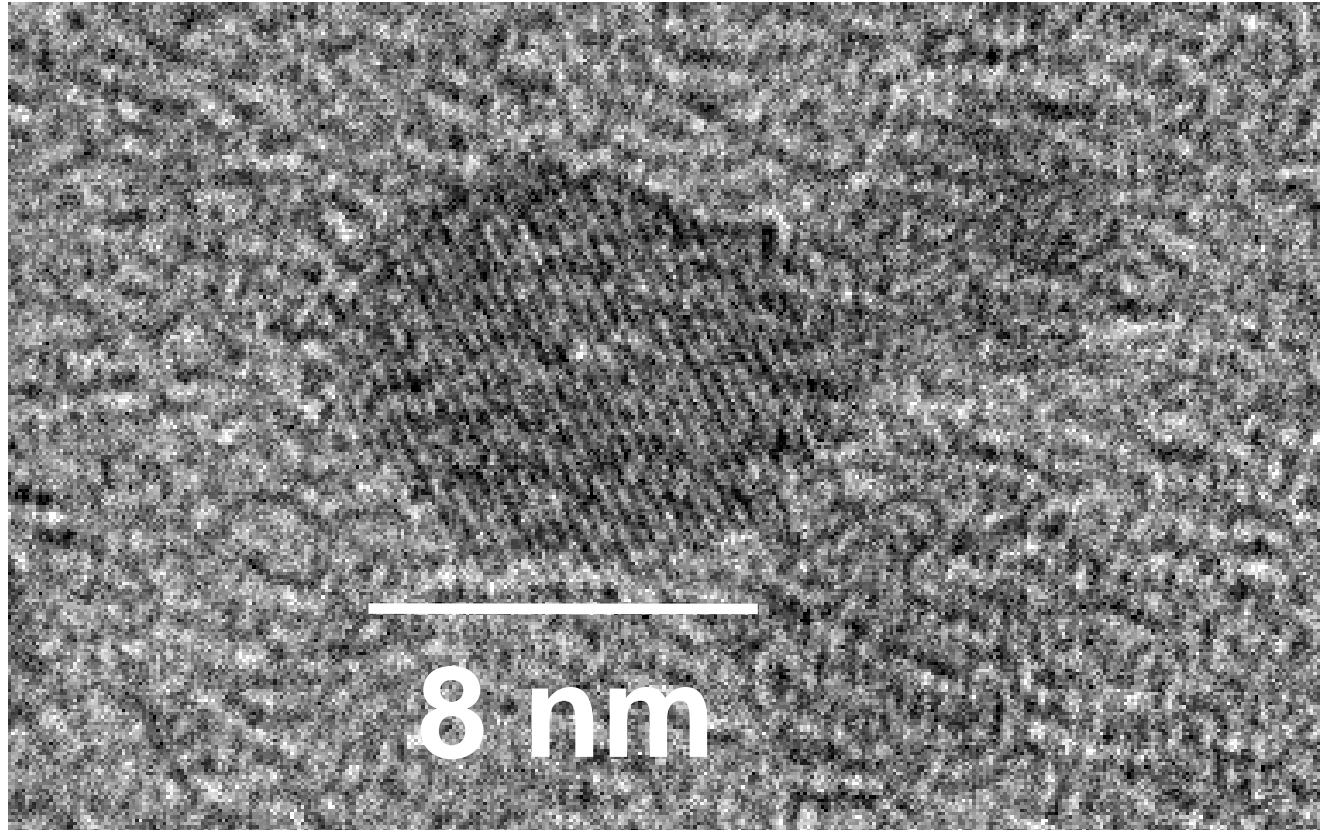

Note the regular crystal structure of the magnetic nanoparticle.

Synthesis of magnetic nanoparticles

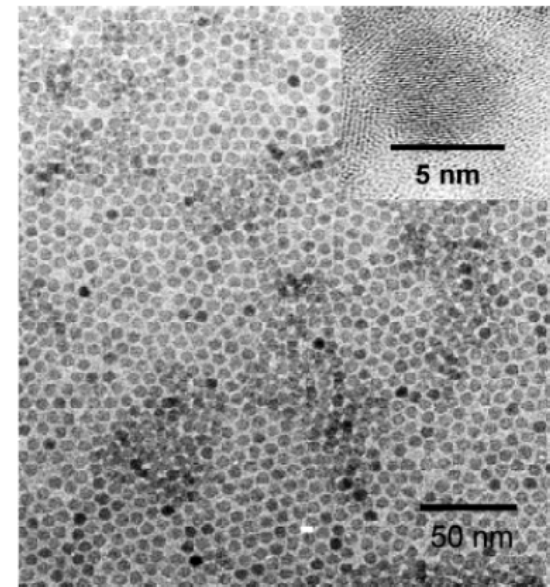
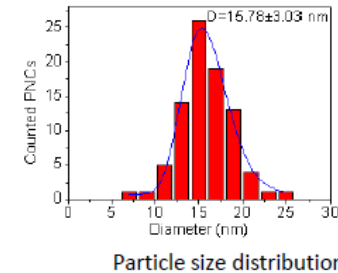
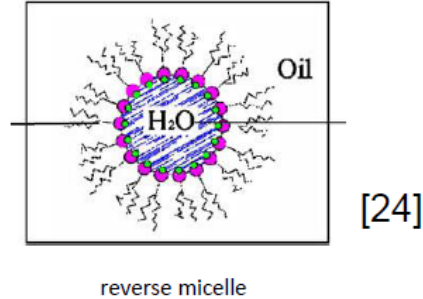
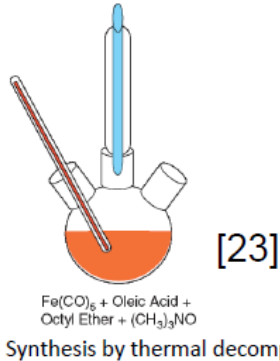

Low-resolution TEM image and high-resolution TEM image of a single nanocrystallite (inset) of 7 nm γ -Fe₂O₃ nanocrystallites.
T.Hyeon et al., J. Am. Chem. Soc. 2001, 123, 12798-12801

Materials:

- ferromagnetic metals (Fe, Co, Ni),
- alloys (FeCo, FeNi, FePt, CoPt, NdFeB, SmCo)
- oxides (Iron oxides, CoO, Co₃O₄)

Requirements:

size control and narrow size distribution

Prepared by a variety of methods, broadly:

- coprecipitation,
- thermal decomposition
- microemulsion (or reverse micelle method).

Supramolecular Clusters

Controlled hydrolytic polymerization of iron. Iron-core growth arrested via surface passivation with benzoate ligands. **Observation of novel magnetic behavior.**

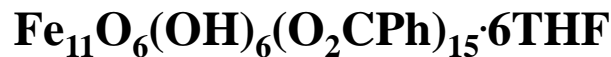
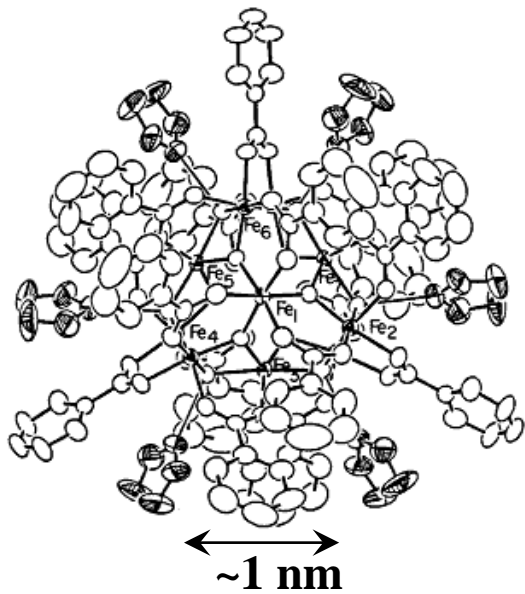

G. C. Papaefthymiou, Phys. Rev. B 46 (1992) 10366

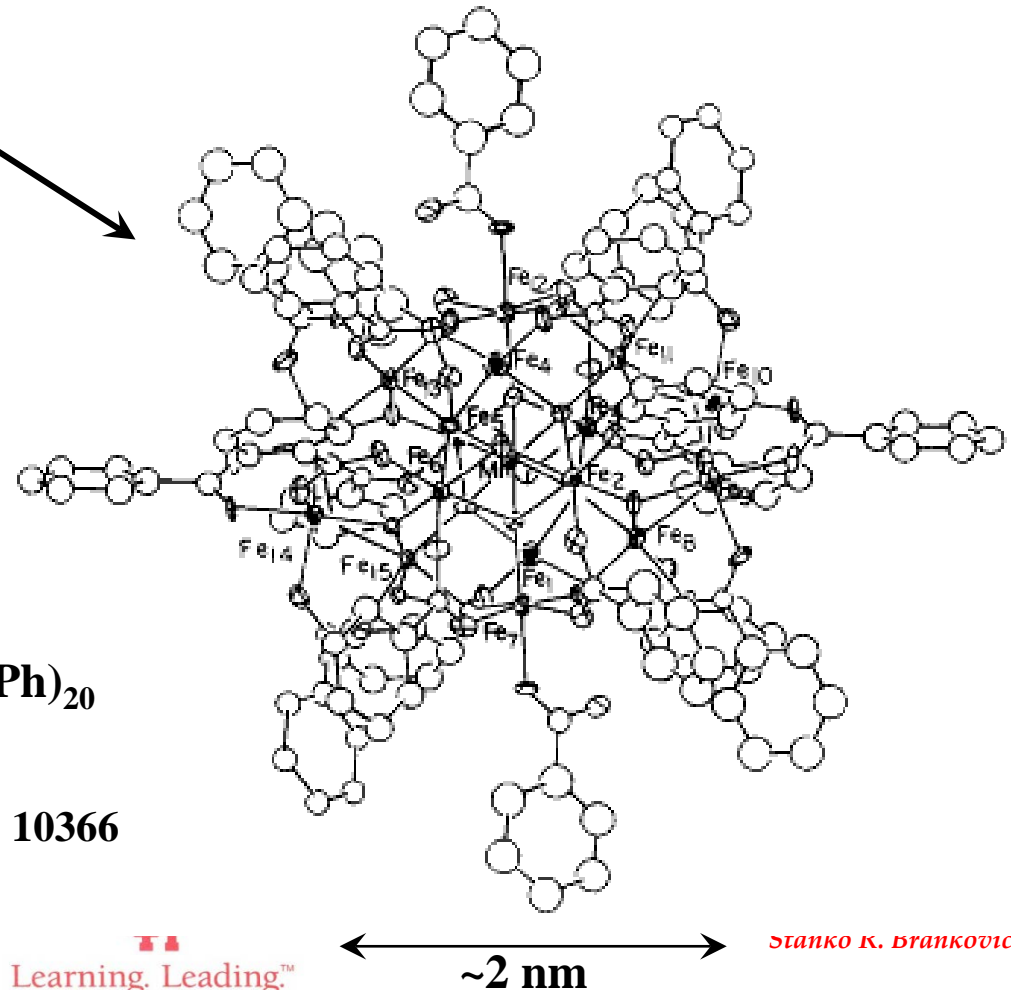

Block Copolymer Nanotemplates

Principles of synthesis

Blocks of sequences of repeat units of one homopolymer **chemically linked** to blocks of another homopolymer sequence.

Microphase separation

due to block incompatibility or crystallization of one of the blocks.

Templates for synthesis and arraying of metal oxide nanoclusters within space confined nanoreactors

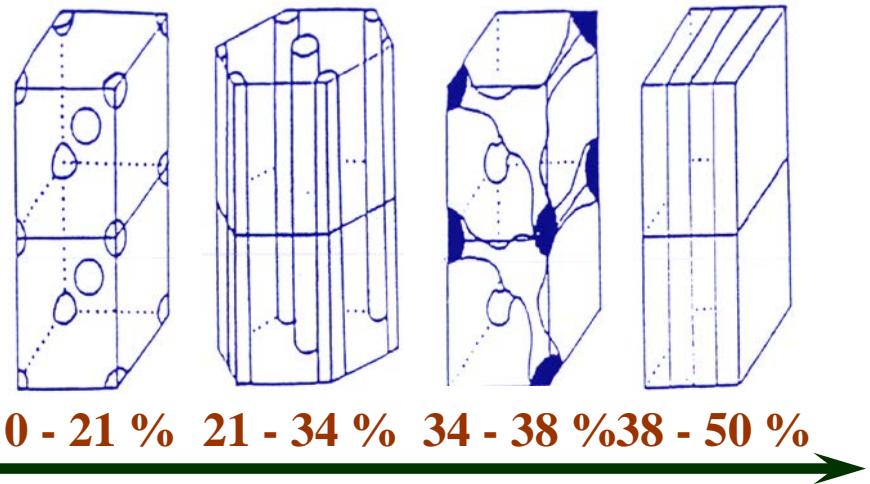
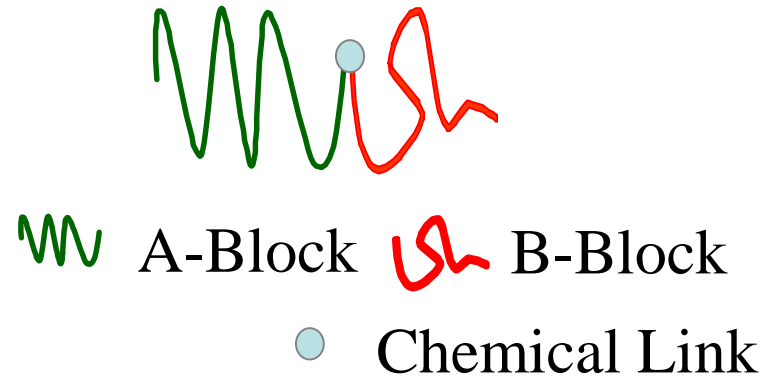

Increasing Volume Fraction of Minority Component

Cobalt Ferrite Nanocluster Formation within Block Copolymers

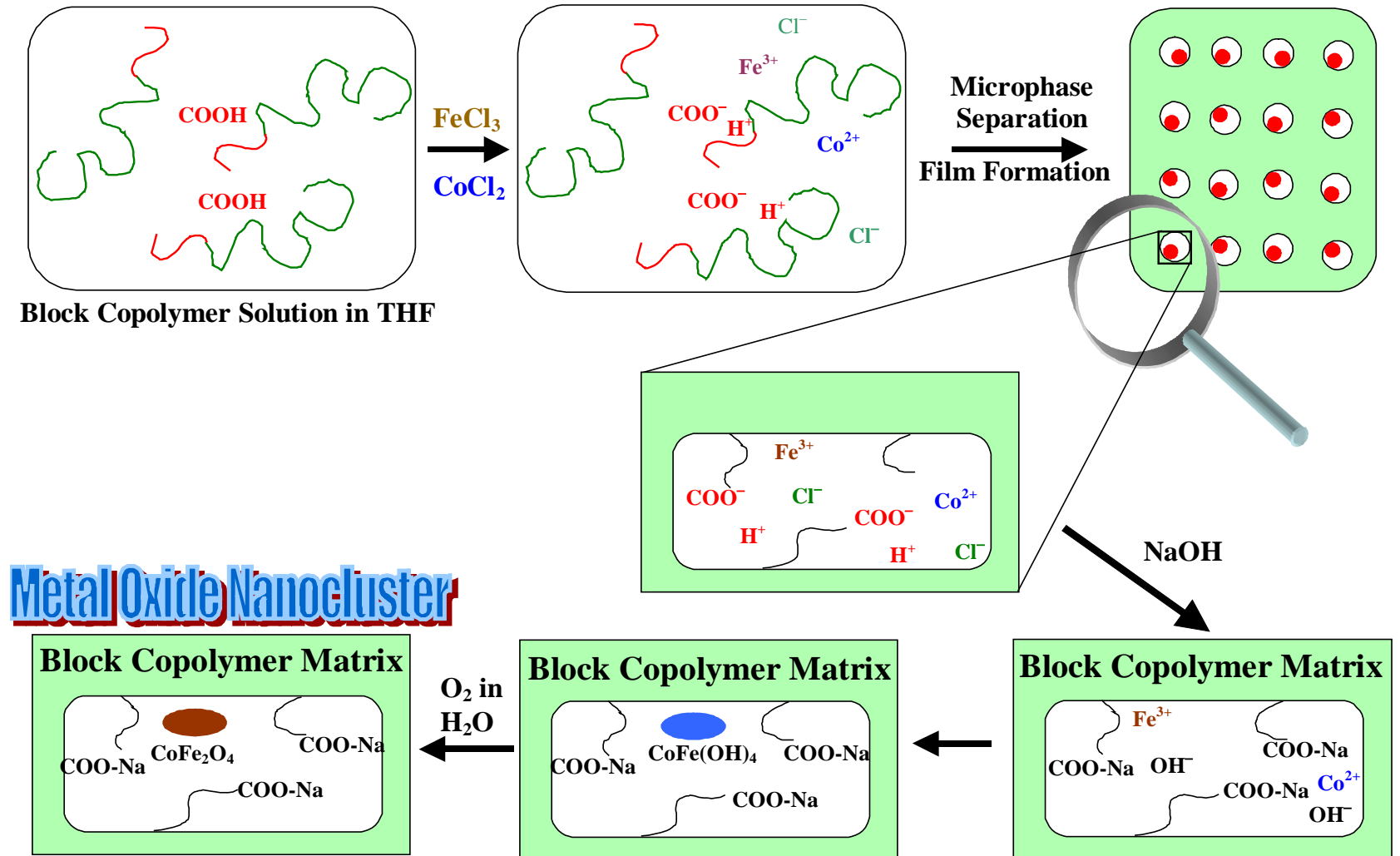

G.C. Papaefthymiou, S.R. Ahmed and P. Kofinas Rev. Adv. Mater. Sci. 10 (2005) 306

CoFe₂O₄ Block Copolymer Films

Transmission Electron Microscopy

Morphology of block copolymer films: ensemble of **polydispersed** CoFe₂O₄ nanoparticles, oval in shape and of average diameter of 9.6 ± 2.8 nm.

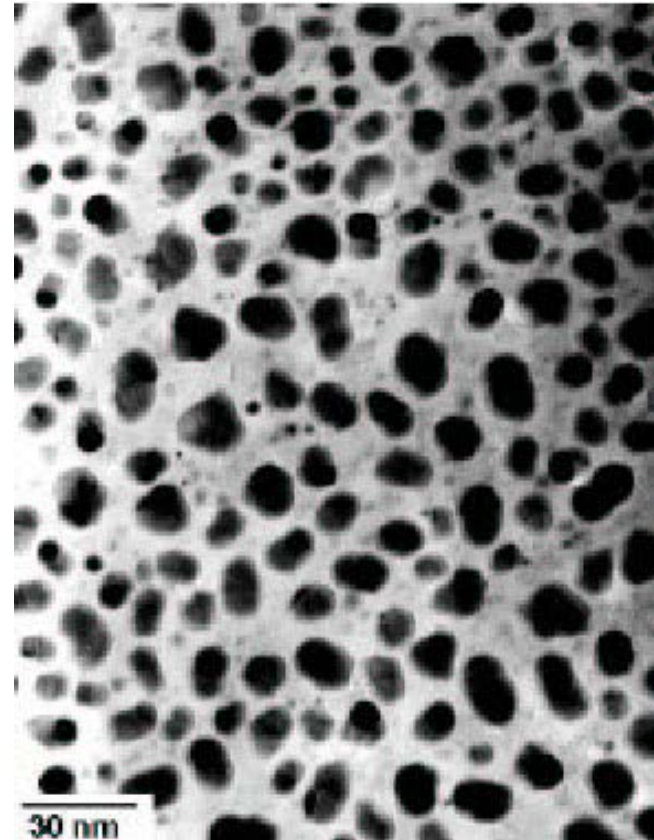

Ahmed, Ogal, Papaefthymiou, Ramesh and Kofinas, Appl. Phys. Letts 80 (2002) 1616

Two-dimensional Array of Ferritin

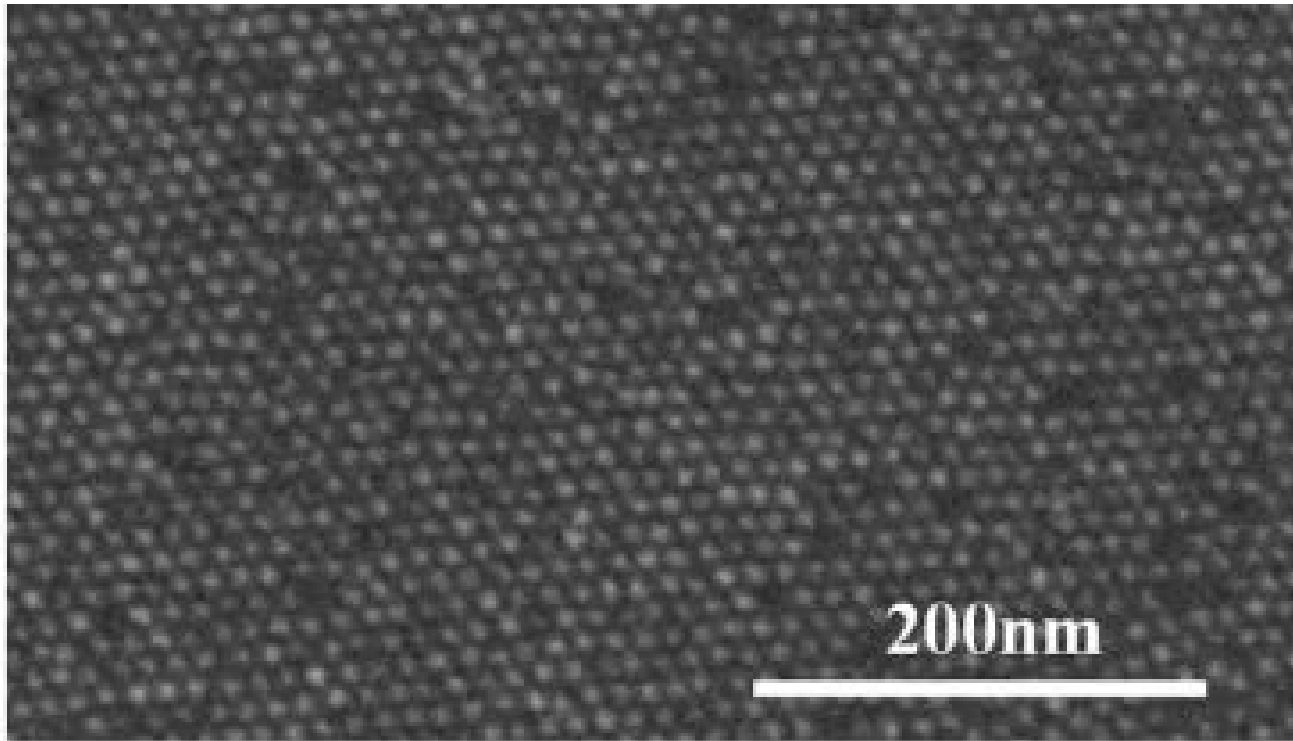

Ensemble of
monodispersed
magnetic
nanoparticles

Fig. 2. An H-SEM image of the two-dimensional array of ferritin on Si substrate. The array is transferred onto the Si substrate coated with a hydrophobic layer. The white dots represent the iron oxide cores of the ferritin molecules and make a well-ordered two-dimensional array. The distance between cores is approximately 12 nm.

I. Yamashita *Thin Solid Films*, 391 (2001) 12

Schematic of the synthesis of MP/SiO₂/MS nanoarchitectures

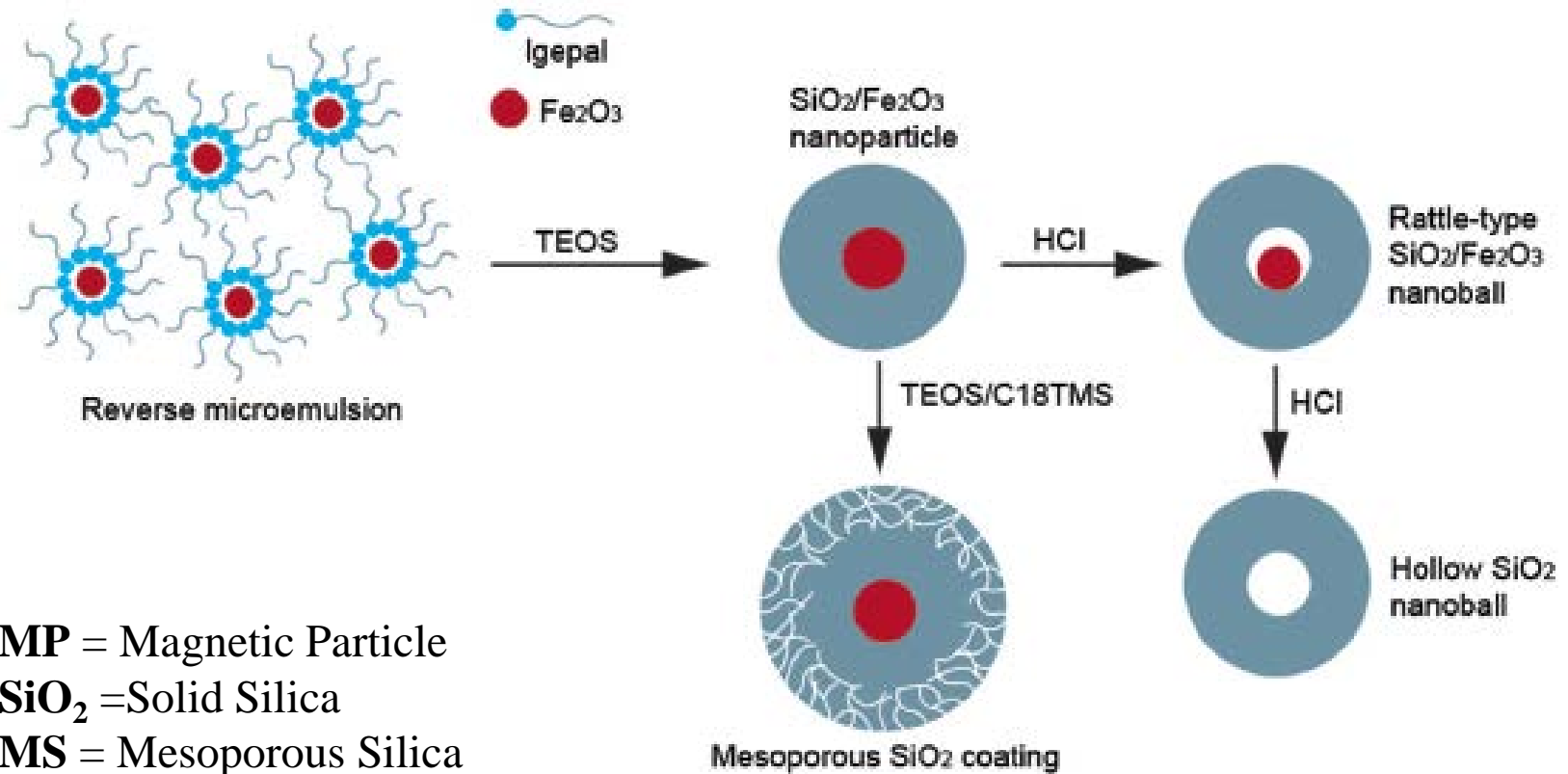

Solid-silica coated γ -Fe₂O₃ nanoparticles

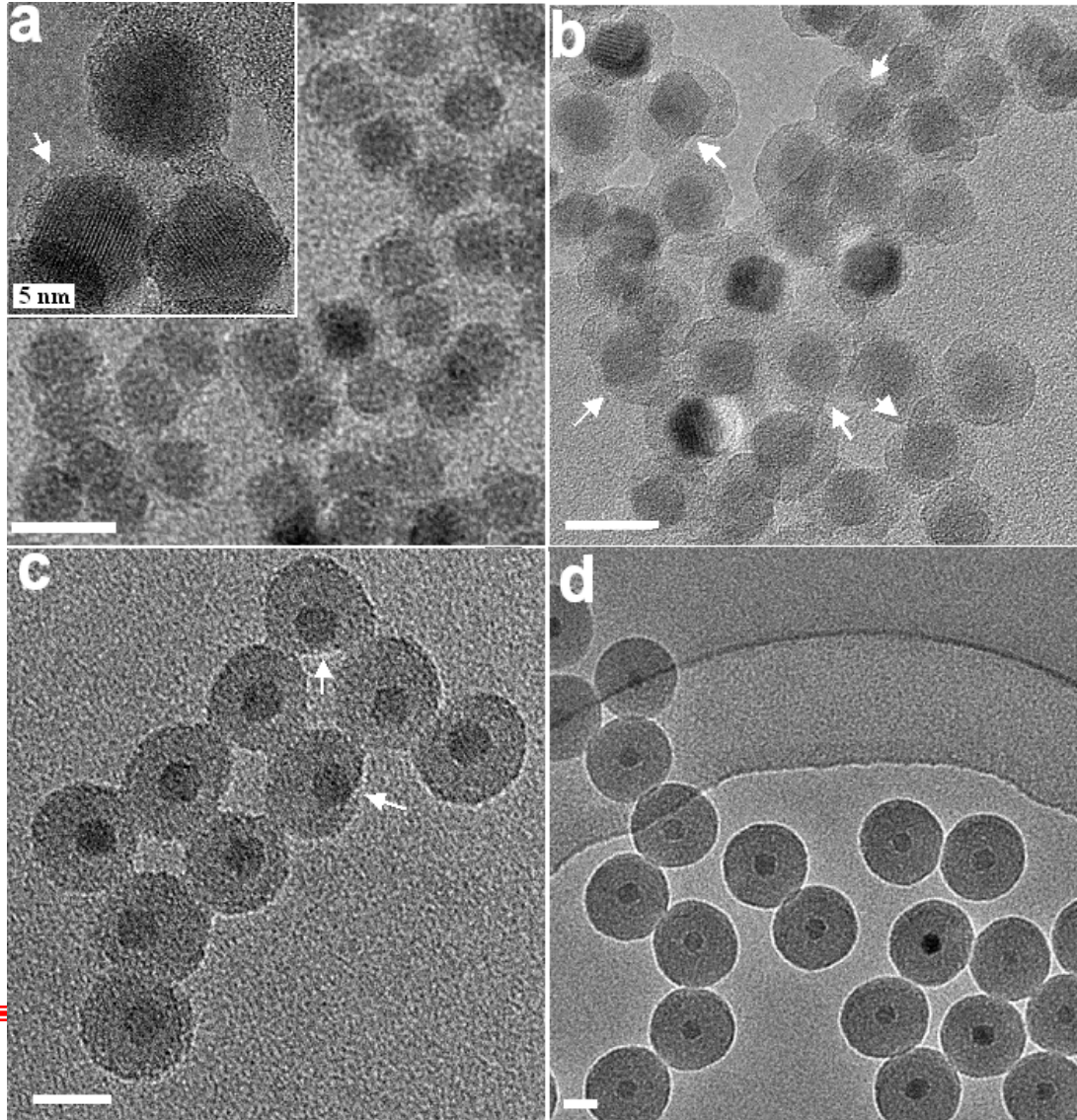

TEM micrographs of ~ 12 nm γ -Fe₂O₃ particles covered with solid silica shell. Shell thickness from 1.8 nm to 25 nm was achieved. Scale bar 20 nm

D.K. Yi, S.S. Lee, G.C. Papaefthymiou, J.Y. Ying,
Chem. Mater. 18 (2006) 614

Stanko R. Brankovic

Higher Nanoarchitectures

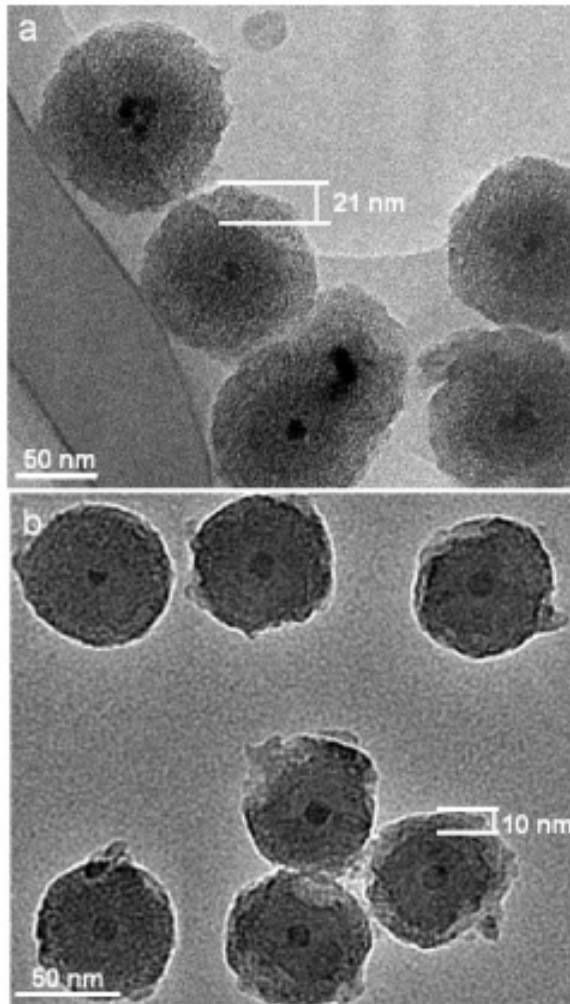

TEM micrographs of γ -Fe₂O₃ core-solid silica shell-mesoporous silica shell nanocomposites

~ 12 nm maghemite particles were used as templates

(a) A thick mesoporous layer (~21 nm) was obtained using a mixture of TEOS and C18TMS, 260 μ l and

(b) a thinner mesoporous layer (~10 nm) was obtained using a mixture of TEOS and C18TMS, 120 μ l.

In both cases, (a) and (b), ca. 25 nm solid silica shell coated Fe₂O₃ core-solid silica shell nanocomposites were used as templating cores.

Magnetic nanoparticles applications

Nanoparticles made from magnetic materials are, rather unsurprisingly, referred to as “magnetic nanoparticles”.

This particles can be moved by applying magnetic fields, which allows them to be controlled inside the body.

Magnetic nanoparticles suspended in solution are called “ferrofluids” and have many applications in medicine, acoustics, and electronics.

Iron oxide (Fe_3O_4 , $\gamma\text{-Fe}_2\text{O}_3$). Very stable and easy to synthesize. Biocompatible, minimally toxic, used in many clinical studies, and FDA approved for some applications. Reasonably large saturation magnetization (~ 90 emu/g). The most widely investigated type of magnetic nanoparticle for biomedical applications.

Nanosensors-biosensors

- Biosensor: analytical device for measurement of a specific analyte
- biological material + physicochemical transducer (electrochemical, optical, thermometric, piezoelectric, magnetic or micromechanical)
- Nanomaterials and nanosensors increase sensitivity and detection level to pico-, femto-, atto- and even zepto- scales (10^{-12} to 10^{-21}) – this facilitates early disease detection.
- Biomarkers, molecules with a function indicating physiologic or pathologic state, interact with specific receptors fixed onto the surface of a biosensor transducer.

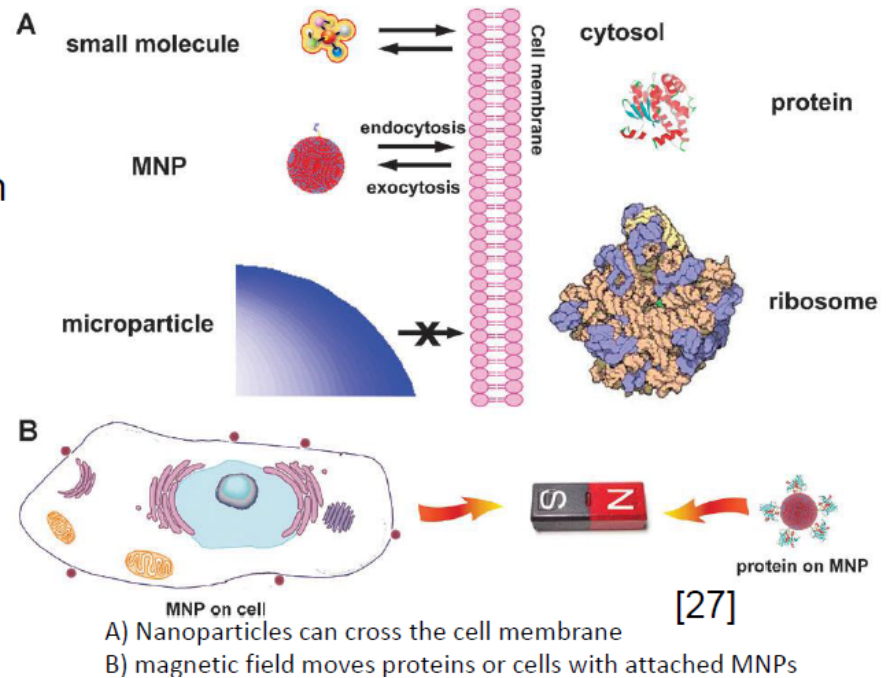
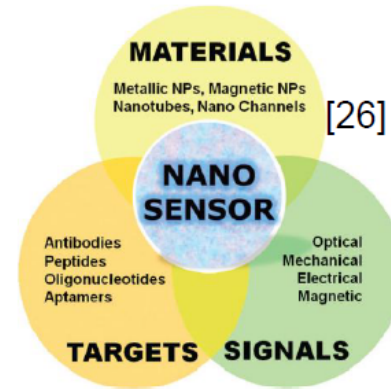

The advantage of magnetic nanoparticles in biomedicine

- Besides detection, the additional advantage of magnetic particles lies in the inherent ability to respond to a static or ac magnetic field: **manipulation** by magnetic field gradient (magnetic carriers, separation), additional **local magnetic field** (MRI) and **energy transfer** (hyperthermia).

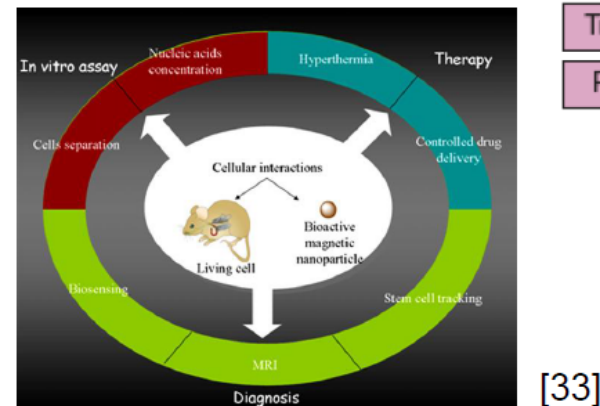
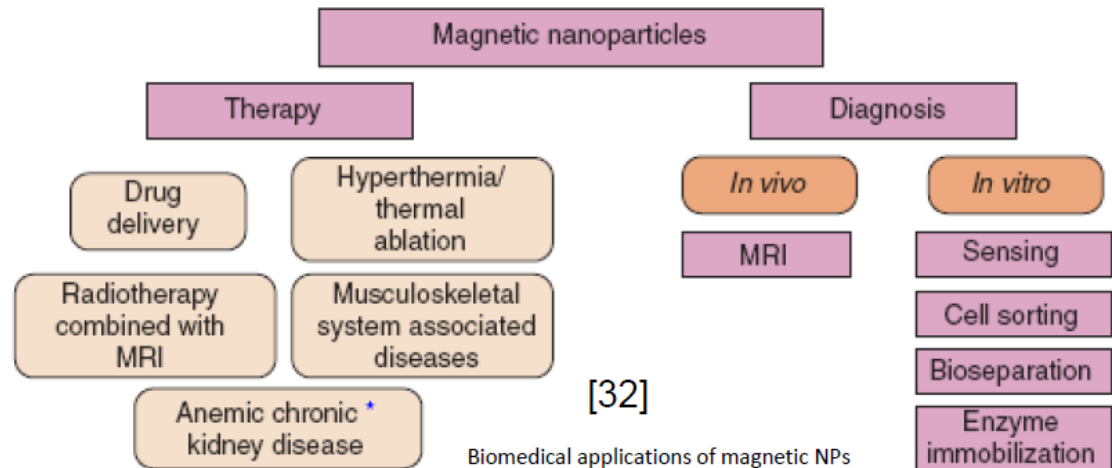

Functionalization- surface modification

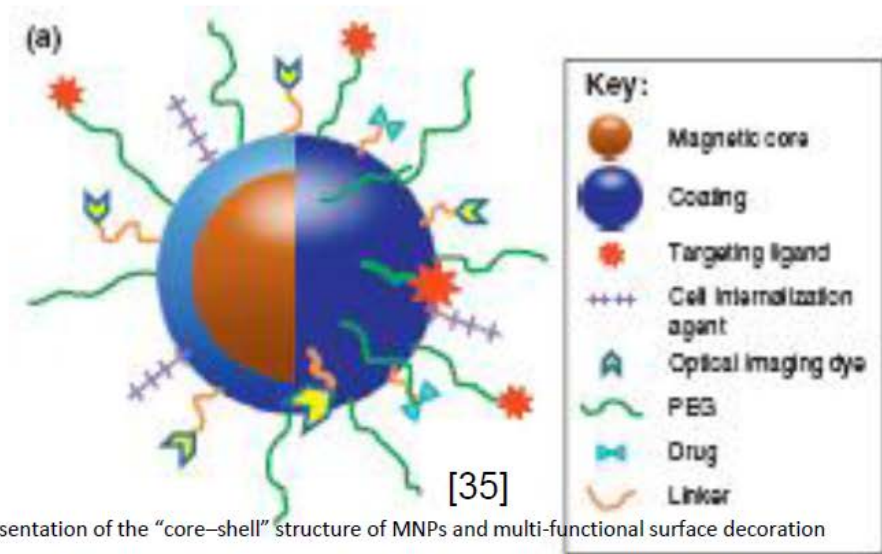
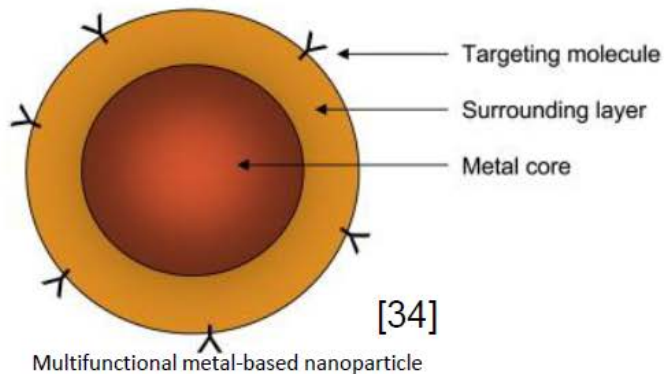

- surface modification required to introduce proper functionality
- only iron oxides are chemically stable (and biocompatible[?])
- multiple functionalities at the same particle: luminescence, conjugation of biomolecules, drug transport and release, amphiphilicity

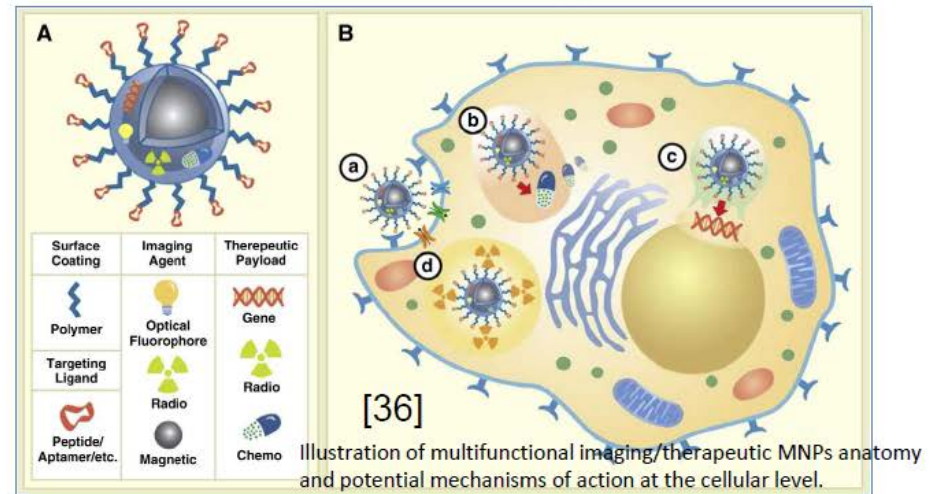

Functionalization- surface modification - 2

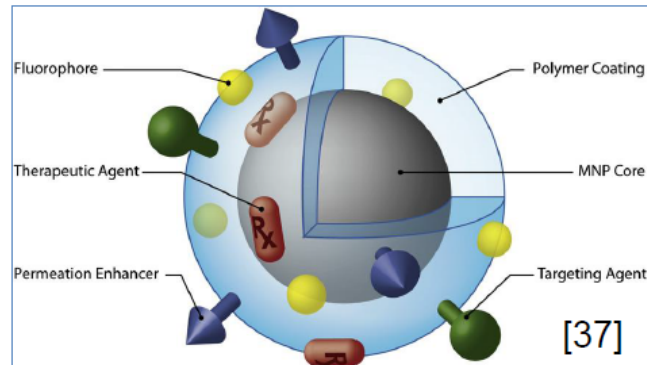

Multifunctional MNP with various ligands

- Surface coating or encapsulation creates a nanocomposite material with (magnetic) core-shell structure, where the shell can be inorganic (e.g. silica), noble metal (Au) or a biocompatible polymer.
- polymers are natural (proteins, sugars, gelatin, chitosan, albumin) or synthetic (polylactic acid, polycaprolactone, poly ethylene glycol - PEG or poly ethylene oxide -PEO) with active sites of biologic or catalytic functions.

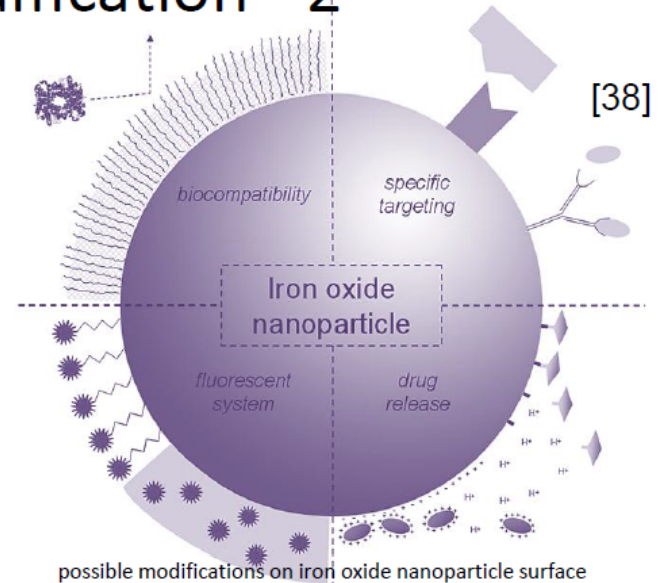

possible modifications on iron oxide nanoparticle surface

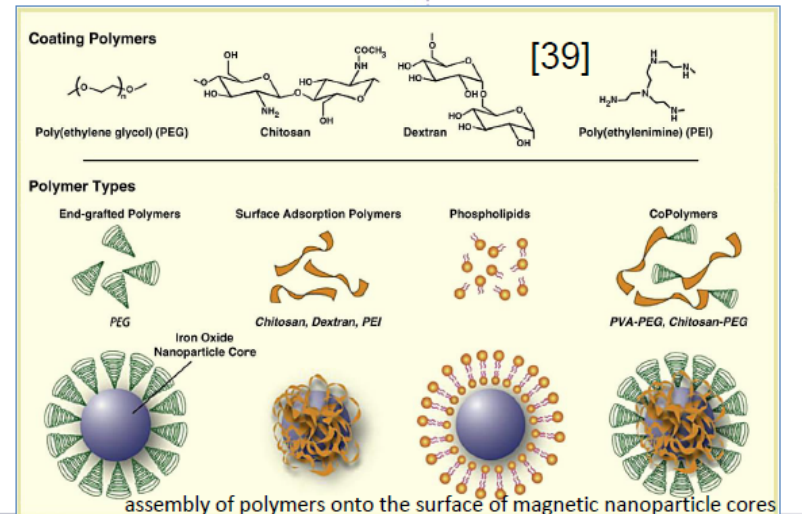

Targeted drug delivery

- Personalized medicine (tailored treatment)
- Release of a therapeutic agent at specific site and rate by means of composite nanoparticles, consisting of the carrier, the bound or encapsulated bioactive payload and surface modifiers
- Advantages over traditional drug administration.
- Passive and active tumour targeting exploits the enhanced permeability and retention (EPR) effect of tumor tissue and the binding function of site-specific surface agents.
- Magnetic carriers are unique as they can be directed and localized under the influence of magnetic field.

When the magnetic forces overcome the linear blood flow rates in arteries (10 cm s^{-1}) or capillaries (0.05 cm s^{-1}), the magnetic particles are retained at the target site and may be internalized by the endothelial cells of the target tissue

Cellular barriers encountered by NPs. Entry into the cell across the cell membrane can occur by direct permeation, or by various types of endocytosis mechanisms.

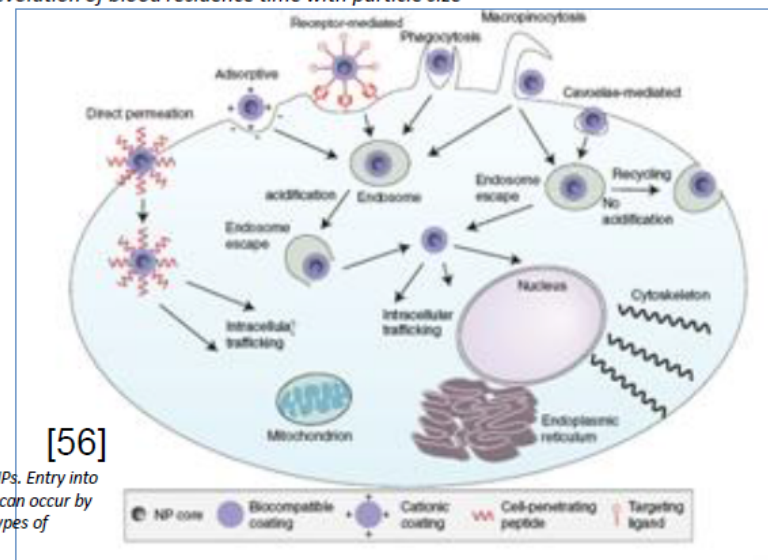
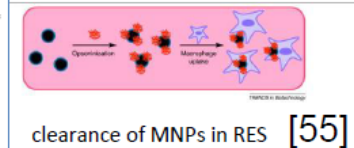
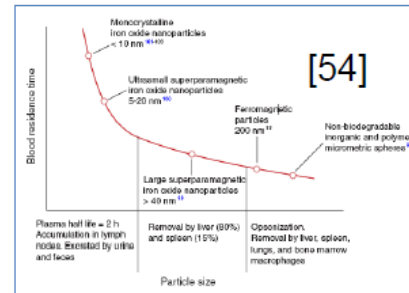
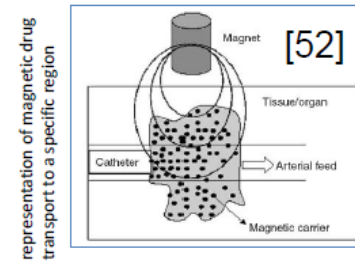

Using magnetic nanoparticles to trigger controlled drug release

Because magnetic nanoparticles show a large response to magnetic fields, they can be used to trigger reactions simply by using external fields. This functionality can be used for controlled drug release.

PNIPAM is a thermosensitive polymer, which has a significant volume collapse near 40 °C.

By integrating magnetic nanoparticles with PNIPAM, the resulting composite can be heated using external ac magnetic fields, which in turn can trigger the volume change.

This phenomenon can be exploited for controlled drug delivery. A drug that can be stably loaded into the PNIPAM matrix at low temperatures, but exits at high temperature, can be released by the expedient of applying a magnetic field.

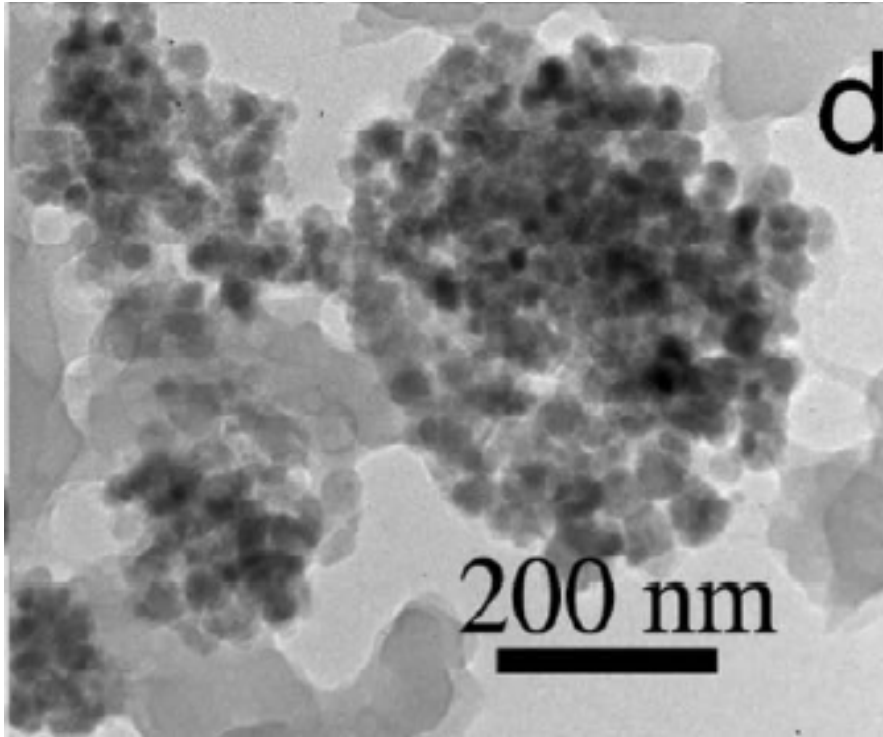

TEM image of magnetic nanoparticles attached to the surface of the PNIPAM microgel.

The magnetic nanoparticles seem to preferentially coat certain PNIPAM globules, rather than being distributed uniformly.

This may degrade the controlled response (as only a portion of the PNIPAM is targeted).

Drug release in PNIPAM and PNIPAM/Fe₃O₄ composites

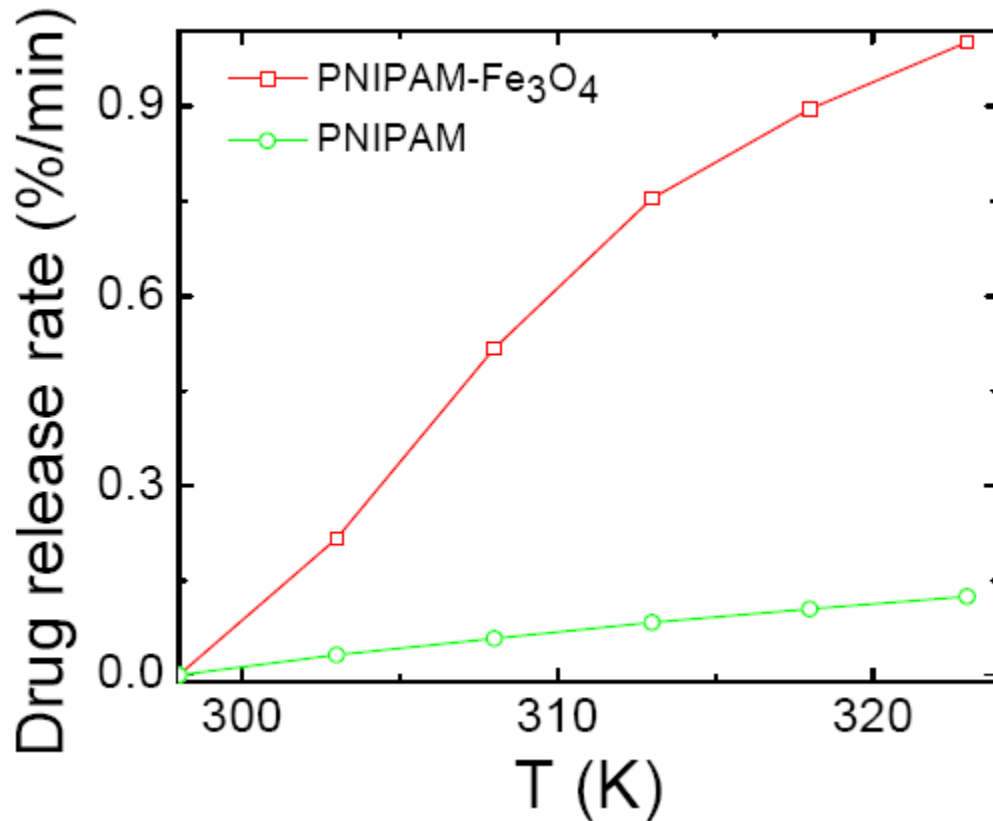

Drug release rate from magnetically heated PNIPAM/Fe₃O₄ composite is much higher than from pure PNIPAM heated in a water bath.

Surprisingly, there is no significant change in the release rate associated with the structural transition (in either sample).

Points to importance of understanding chemical interactions in detail.

MNPs in Alzheimer disease (AD) theragnostics

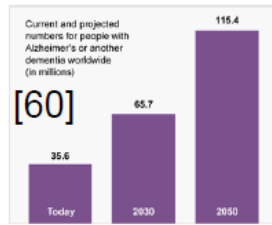

Source: 2009 World Alzheimer Report, from Alzheimer's Disease International (ADI), a London-based nonprofit, international federation of 71 national Alzheimer organizations including the Alzheimer's Association

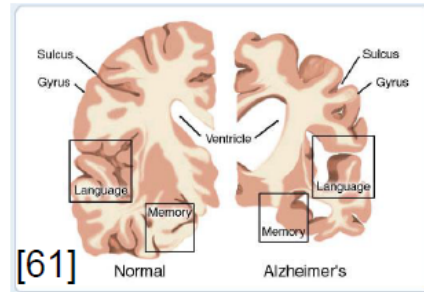

[61] cross-section of the brain as seen from the front

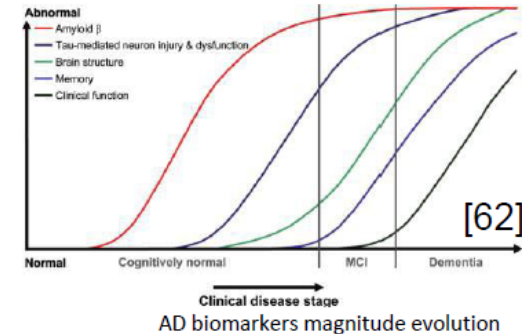

- Alzheimer-type dementia affects more than 18 millions of people, a number estimated to double in the next 20 years.
- Currently there is no cure and treatments aim at managing the condition or slowing the progression of the disease.
- Diagnosis of AD employs cognitive tests and brain MRI. A β amyloid fibril and plaque depositions in neural cells of the brain (mainly at hippocampus and amygdala) are associated to the AD pathology, while A β oligomers are considered as the neurotoxic agents.
- Development of biomarkers for A β amyloid, exploiting the advantages of magnetic carriers, may contribute to research for early stage diagnosis and screening of AD.

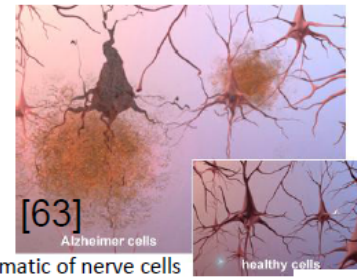

[63] Schematic of nerve cells

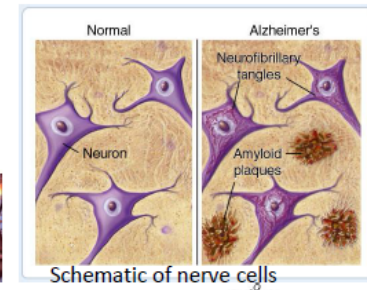

[64]

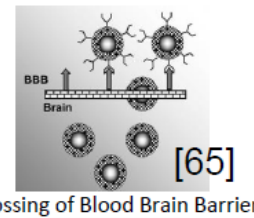

[65] NP crossing of Blood Brain Barrier

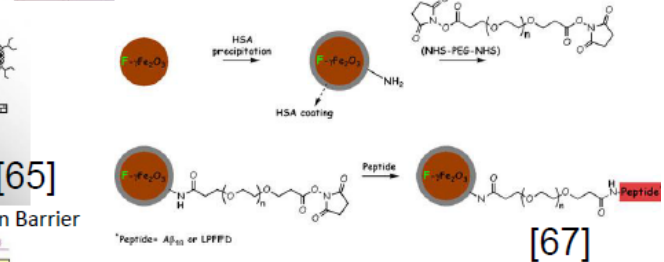
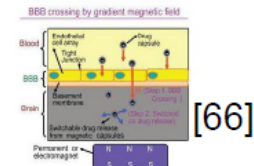
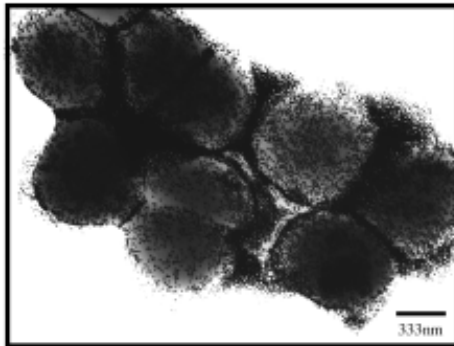

Fig.6 Covalent conjugation of the Ab40 and the LPPFD peptides to the F- γ -Fe $_2$ O $_3$ nanoparticles, *J Nanopart Res (2011) 13:3521–3534*

Nanoparticles in action

A. Modifying a ferromagnetic nanoparticle with human immunoglobulin G (IgG), which specifically binds the protein A in the cellular wall of *staphylococcus*, the bacteria can be detected through a MRI test

B.



Accumulation of functionalized ferromagnetic nanoparticles on staphylococcus

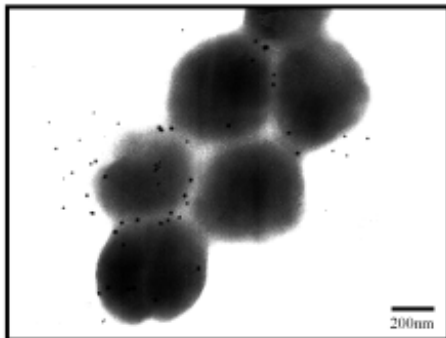

Negligible accumulation of nanoparticles in absence of functionalization

C.

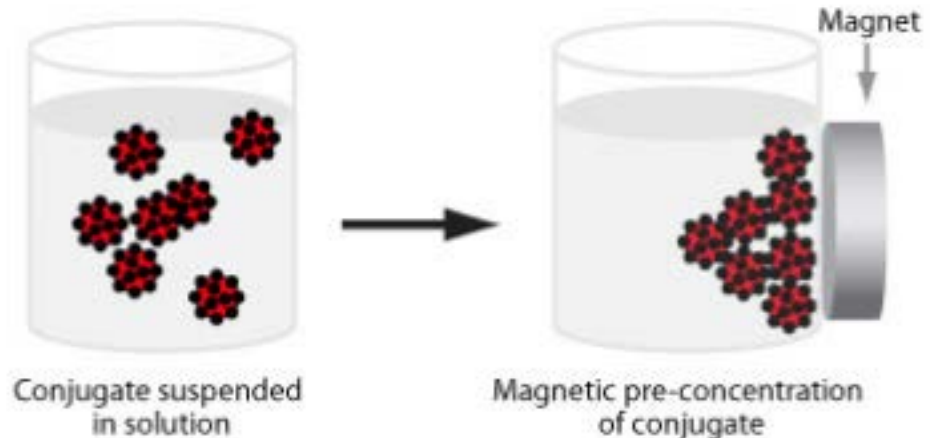
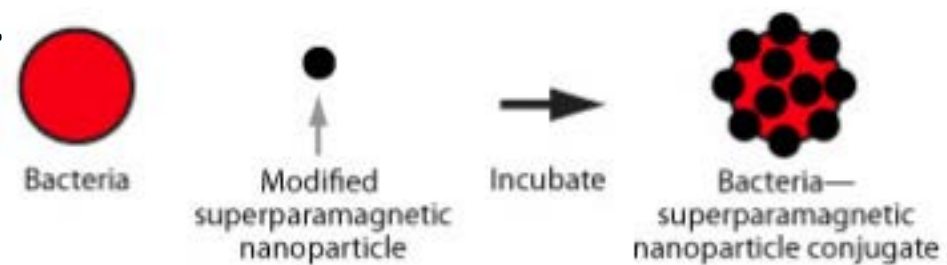

Directed accumulation of dangerous bacteria by conjugation with functionalized magnetic nanoparticles

Manipulation

- most biological samples have negligible magnetic susceptibility
- magnetic field gradient : manipulation of magnetic particles with contactless forces
- Technique already employed with micrometer size magnetic beads in cell or protein separation
- Nanoparticles are faster and more active, and may cross easily the cell membrane by endocytosis.
- They have a size comparable to cell organelles and other biological targets, to which they attach, functionalised with suitable ligands or with antibodies.
- Demonstrated applications include capture and detection of pathogens, cell sorting (separating/isolating), capture of stem cells, in vivo cell targeting and extraction, cell destruction, cell migration control.

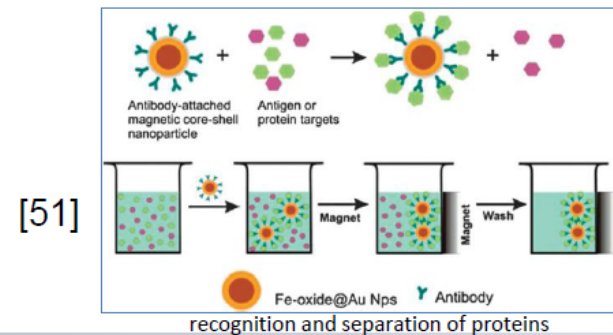
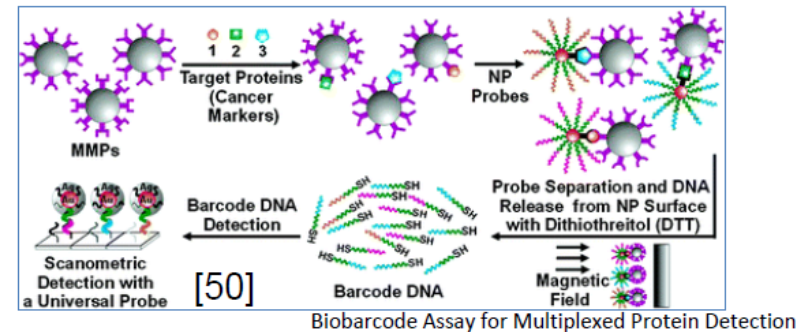
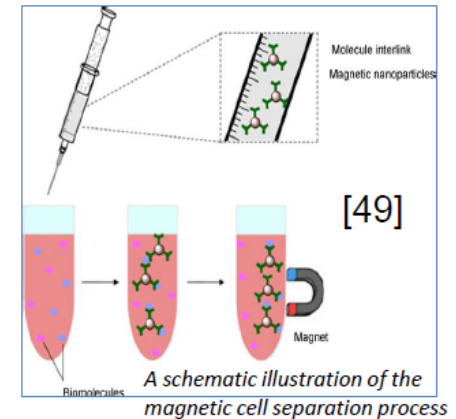
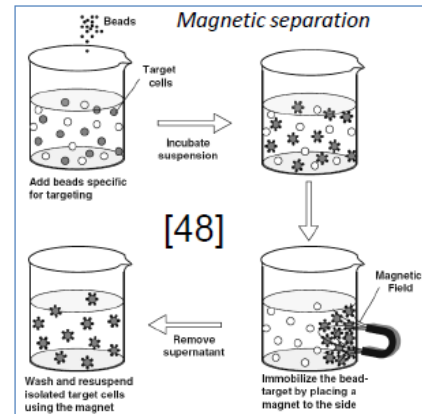

Relaxation in magnetic nanoparticles

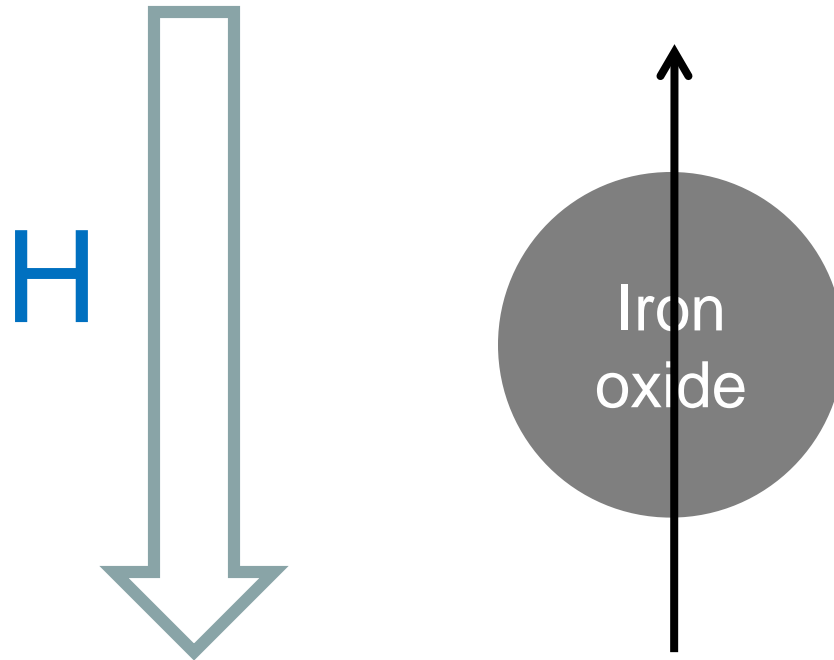

In Brownian relaxation, the entire nanoparticle rotates to reverse the direction of the magnetic moment.

Brownian Relaxation

Relaxation in magnetic nanoparticles

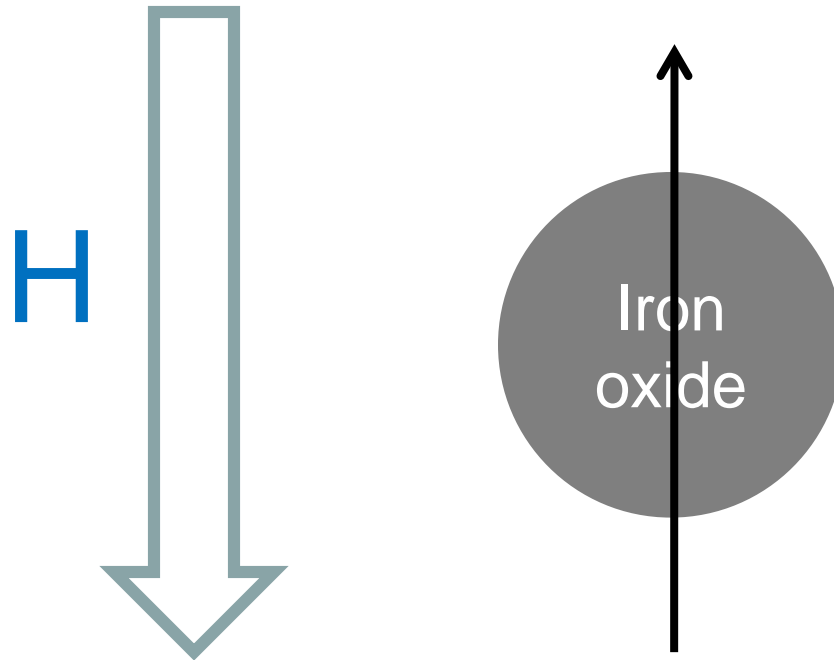

In Neel relaxation, the nanoparticle remains fixed in place, but the magnetic moment reverses direction to align with the external field.

Neel Relaxation

Magnetic hyperthermia

There are a number of therapeutic benefits in producing localized heating, for example, delivering toxic doses of thermal energy to tumors, or increasing the efficacy of certain anti-cancer drugs.

However, heating the surrounding tissue can also produce unwelcome side-effects so there are advantages to strictly controlling the region under treatment by using magnetic nanoparticles as the heating element.

For treating cancer tumors, the general measure of effectiveness is the cumulative equivalent minutes at 43 °C for 90% of the tumor volume (CEM 43 T₉₀).

The magnetic moments on nanoparticles will align with an external magnetic field. As the external field changes direction, the magnetic moment will also change direction. This produces dissipation leading to heating. One of the major advantages of using magnetic fields to produce heating is that they readily penetrate tissue.

Practical aspects of magnetic hyperthermia

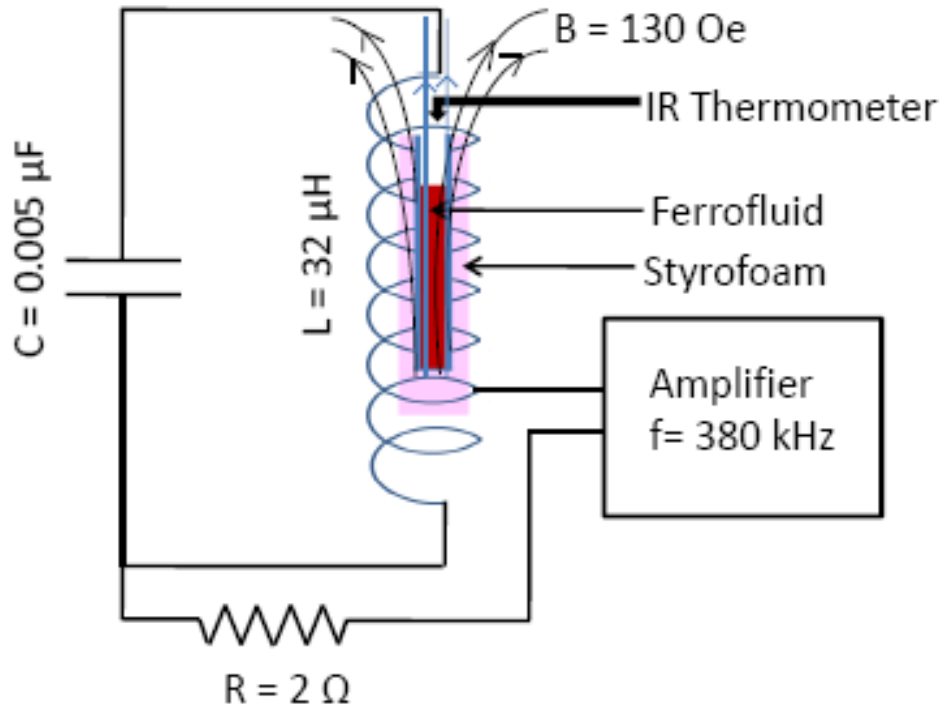

Magnetic hyperthermia requires large magnetic fields alternating at high frequencies to be effective. In practice it is challenging to meet these two requirements simultaneously.

The circuit diagram on the left shows one approach to designing apparatus suitable for hyperthermia. This particular system provides a field of just over 0.01 T at a frequency of almost 400 kHz (with a current of $\sim 30 \text{ A}$ flowing in the wire).

The high currents required for producing high magnetic fields lead to substantial resistive losses in the coil, and therefore significant radiative heating. This must be minimized to avoid heating the entire sample volume (e.g. by water cooling, etc).

Magnetic hyperthermia

- Tumour tissue has reduced thermoregulation ability.
- Local temperature rise to 41-43 °C, besides a decrease of nutrient blood flow, has a direct cytotoxic effect or damages cell structures.
- Additionally, the temperature rise may enhance the effect of anticancer drugs.
- Targeted heat delivery for cancer treatment, alone or in synergistic combination with chemotherapy or radiotherapy drug delivery, is accomplished by superparamagnetic nanoparticles, with minimal injury to normal adjacent healthy cells.
- Energy transferred to magnetic nanoparticles by applying a high frequency (in the kHz range) magnetic field of a few kA/m, is converted to heat by the physical (Brownian) motion of the particles and the oscillation of their magnetic moments (Néel relaxation).

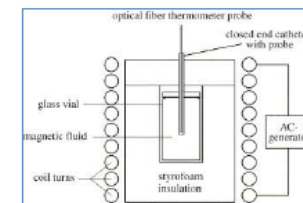
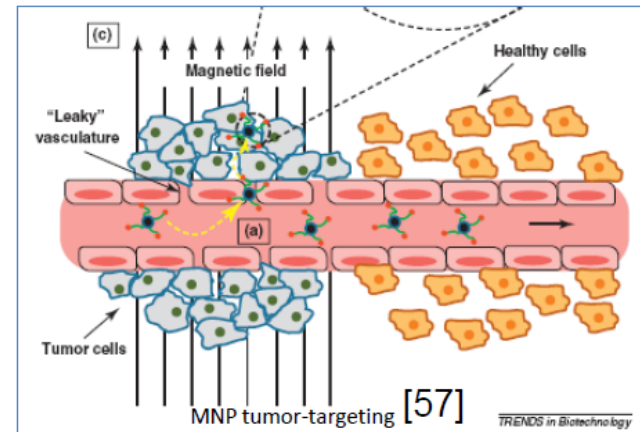

Hyperthermia experimental setup

[58]

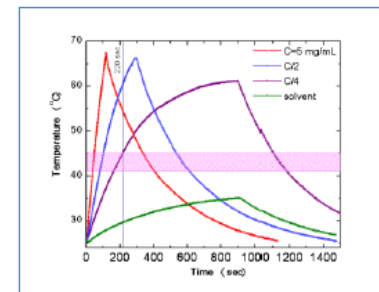

[59]

Concentration dependence of heat and cooling rate

Magnetic hyperthermia

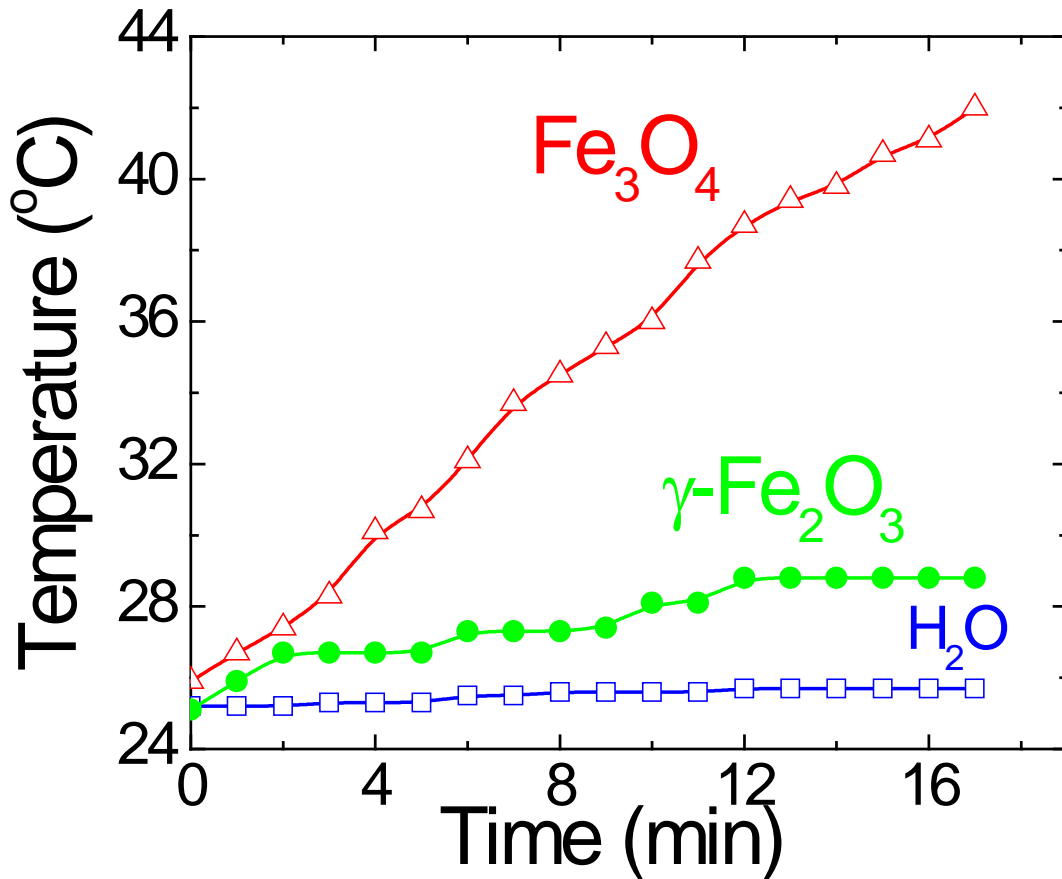

The sample consisting of individual nanoparticles (Fe₃O₄) heats 4-5 times faster than the sample with clustered nanoparticles (γ -Fe₂O₃).

This suggests that, at least for these experimental conditions (nanoparticle size, driving frequency, sample viscosity, etc), Brownian relaxation is a much more effective heating mechanism than Neel relaxation.

Concentration dependence of magnetic heating

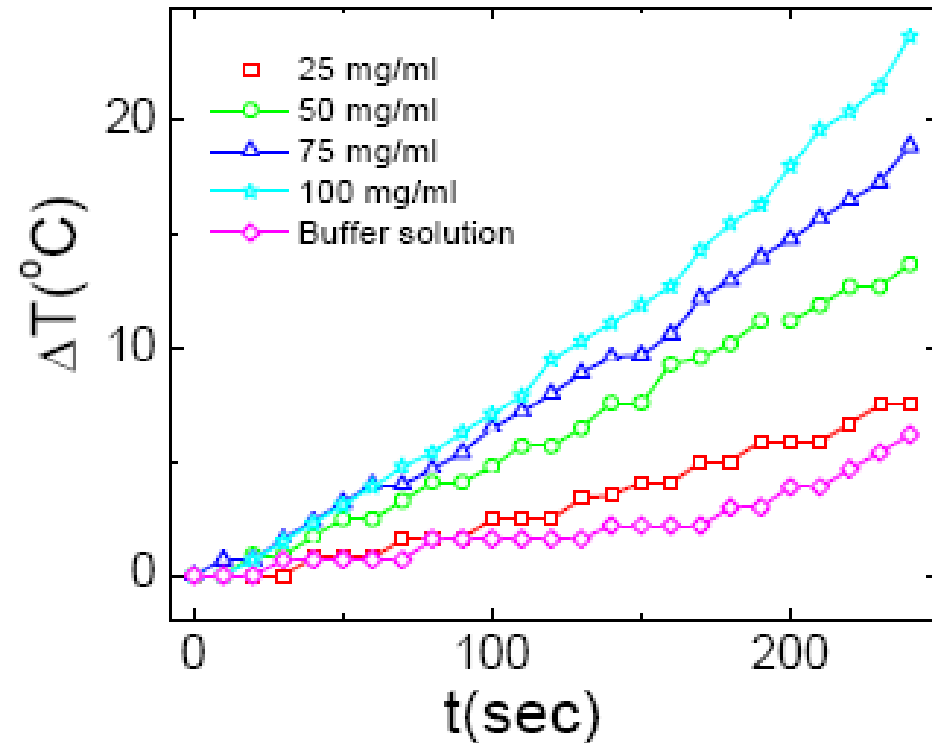

Hyperthermia heating is normally scaled to the heat capacity and expressed as specific absorption rate (SAR) in units of W/kg.

A higher concentration of magnetic nanoparticles will lead to a greater amount of heating during magnetic hyperthermia (as illustrated on the left).

However, increasing the concentration of nanoparticles may lead to increased toxicity and other undesirable side-effects.

Understanding the heat flow from magnetic nanoparticles into the surrounding tissue, and then through the surrounding tissue will be important when designing specific applications.

Magnetic resonance imaging

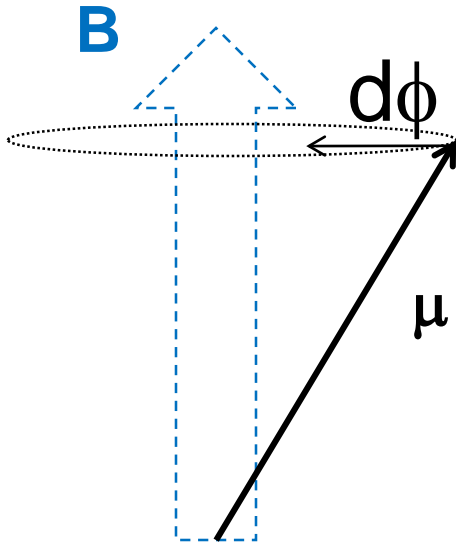

Local magnetic moments (μ) will precess about a magnetic field \mathbf{B} .

The rate of precession will depend on the magnitude of the magnetic field, so is sensitive to the magnetic environment.

Applying a gradient magnetic field over an object produces a gradient in precession rates, which can be correlated with position. This allows local changes in magnetic properties to be spatially localized.

Magnetic relaxation

When the local moments are perturbed, there are two main relaxation effects on the magnetic dynamics.

T1 (Longitudinal relaxation time) is a measure of how long the magnetization takes to recover to align along B after being flipped 90° . This depends on interactions of the moment with other particles and is referred to as “spin-lattice” relaxation.

T2* (Transverse relaxation time) is a measure of how long spins will rotate together when flipped 90° . This is affected by the precession rate, which depends on the local magnetic environment. As T2* relaxation depends on the interaction of moments with the magnetic field, this is referred to as “spin-spin” relaxation.

Different types of tissue have different T1 and T2* relaxation times and can therefore be distinguished using MRI.

Contrast agents modify T1 and T2* and can provide clearer images. Superparamagnetic iron oxide nanoparticles greatly reduce T2*.

Static MR measurements

Quartz tube filled with ferrofluid (Fe_3O_4)

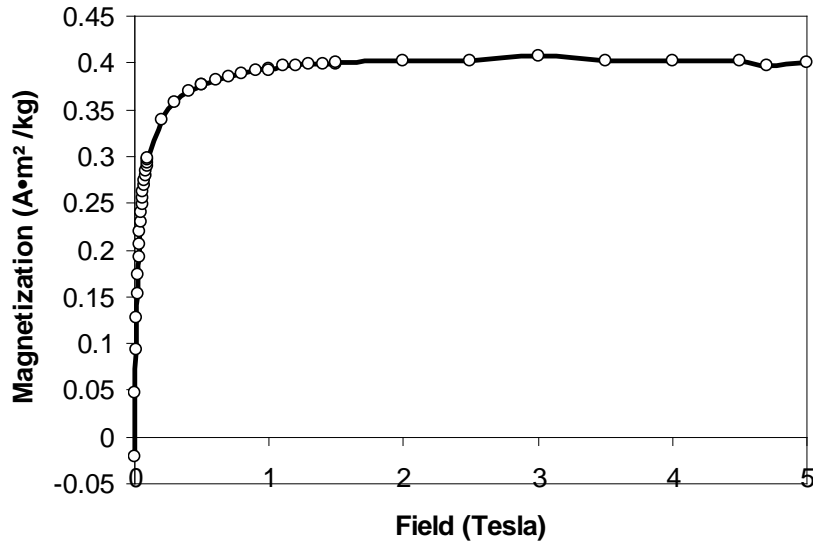

Bulk magnetization data
 $\chi=103$ ppm at 4.7 T

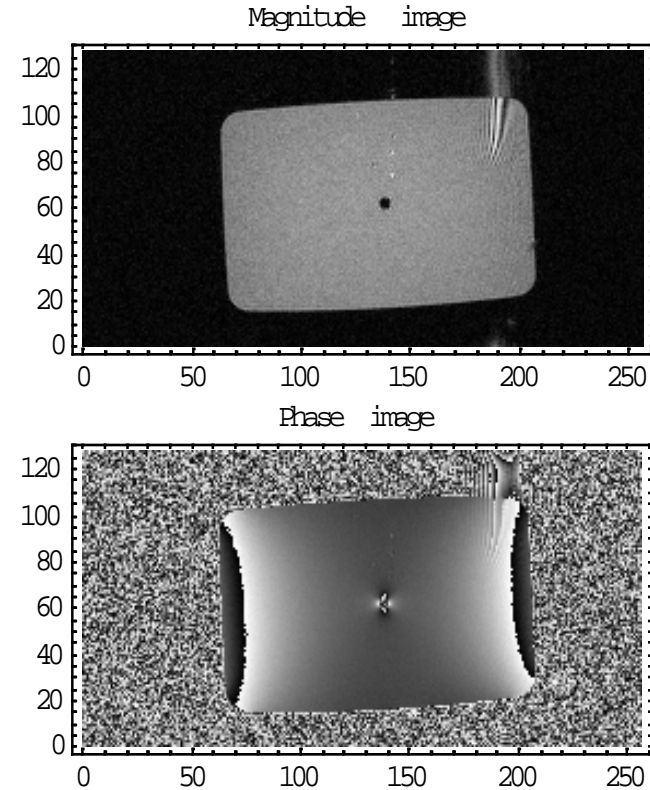

MRI data
 $\chi=112$ ppm at 4.7 T

Direct measurements of the ferrofluid susceptibility agree well with the value extracted from MRI studies. This allows a *quantitative* determination of nanoparticle concentration using MRI.

Imaging – Magnetic Resonance

- non-invasive diagnostic technique for soft tissue imaging.
- The proton magnetic moments of water molecules are aligned by a strong (~1T) steady field in the z-direction, and then excited by transverse rf pulses at resonance frequency, with characteristic T1 and T2 relaxation times.
- T1 corresponds to the relaxation along the field z-direction and results in the loss of energy in the form of heat. This is also known as longitudinal or spin-lattice relaxation. T2, the transverse or spin-spin relaxation, corresponds to relaxation from the precession in the x-y plane.
- Proton (water) concentration depends on tissue constitution and determines the contrast of the obtained image.
- Magnetic nanoparticles are used as contrast enhancing agents, affecting the T1 or T2 relaxation time through the local field they provide.
- Iron oxide-based magnetic nanoparticles, with a size generally between 3 and 10 nm, increase T2 relaxation time and result in darkening of the MRI image.
- Magnetic resonance as benchtop technique has successfully been used in vitro to detect a wide variety of molecular targets with high sensitivity and specificity, including DNA, mRNA, proteins, enzyme activity, metabolites, drugs, pathogens, and tumor cells.

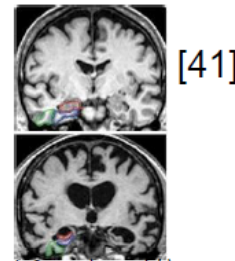
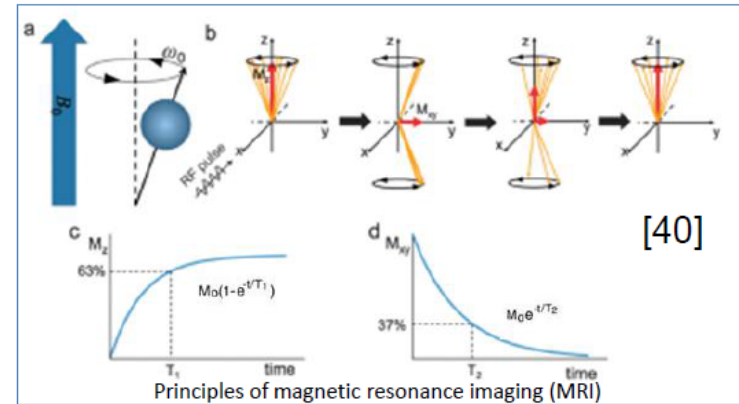

MRI Brain Scans a) normal b) severe atrophy indicative of Alzheimer's Disease

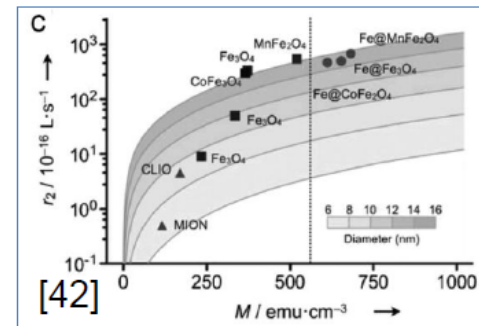
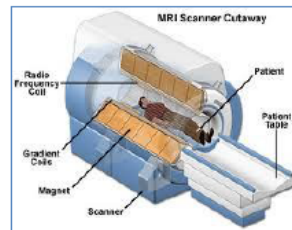

Transverse relaxivity of various ferrite nanoparticles and Fe/ferrite core/shell nanoparticles. The relaxivity of nanoparticles increases with size and magnetization.

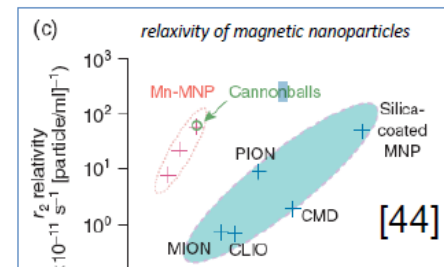

Summary

In addition to being small compared to most biological structures, magnetic nanoparticles have distinctly different magnetic properties from bulk materials, making them potentially very attractive for biomedical applications.

Magnetic nanoparticles have direct applications to medicine, including magnetic hyperthermia and as MRI contrast agents, but can also introduce new functionalities when combined with other materials, such as targeted drug delivery and controlled drug release.

One of the central ideas for magnetic nanoparticle applications is the ability to manipulate the particles using an external magnetic field.

There is still a great deal of work to be done on understanding how magnetic nanoparticles interact with the body (toxicity, excreting the nanoparticles, etc).

Other resources

General reviews

“Applications of magnetic nanoparticles in biomedicine”, Q A Pankhurst, J Connolly, S K Jones and J Dobson, *J. Phys. D: Appl. Phys.* **36** (2003) R167–R181

“Biomedical Applications of Magnetic Nanoparticles”, L. Trahms, *Biomedical Applications of Magnetic Nanoparticles. Lect. Notes Phys.* 763, 327–358 (2009)

Synthesis

“Synthesis and surface engineering of iron oxide nanoparticles for biomedical applications”, A K Gupta, M Gupta, *Biomaterials* **26** (2005) 3995.

Drug delivery

“Magnetic nanoparticle carrier for targeted drug delivery: perspective, outlook and design”, R D K Misra, *Materials Science and Technology* **24** (2008) 1011.

